

(E) HEAD DETAIL
1 1/2" = 1'-0"

*UNITS UNDER 5' IN WIDTH MAY REQUIRE ADDITIONAL WEIGHT BELOW BOTTOM BAR OF UP TO 3/8" THICK

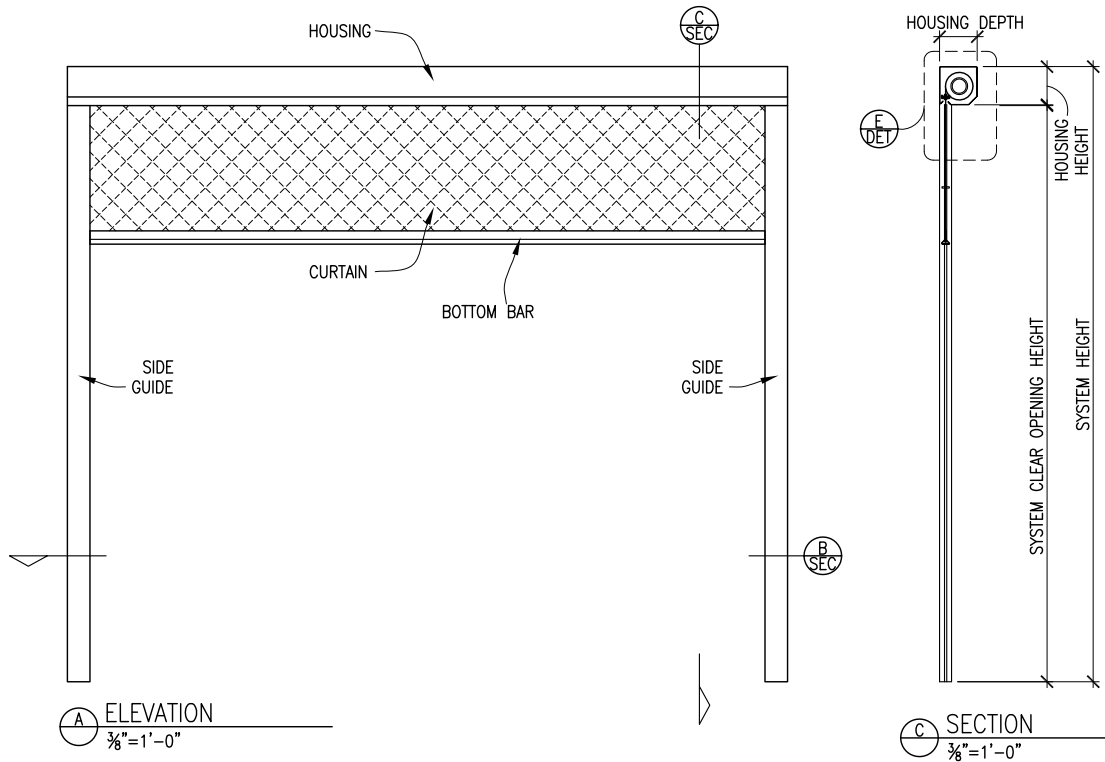

(A) ELEVATION
3/8" = 1'-0"

(C) SECTION
3/8" = 1'-0"

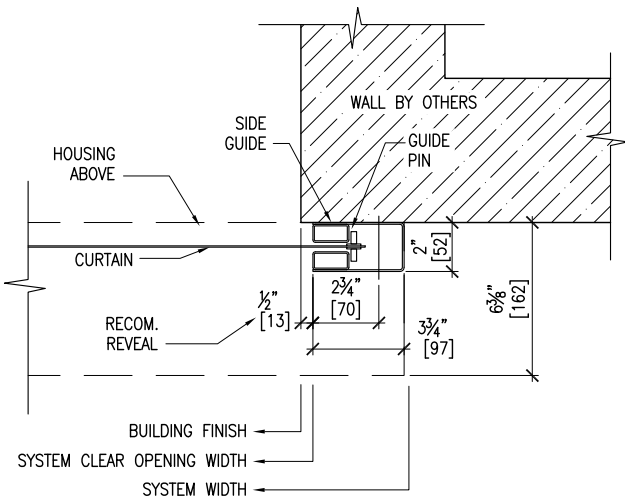

(D) GUIDE DETAIL
1 1/2" = 1'-0"

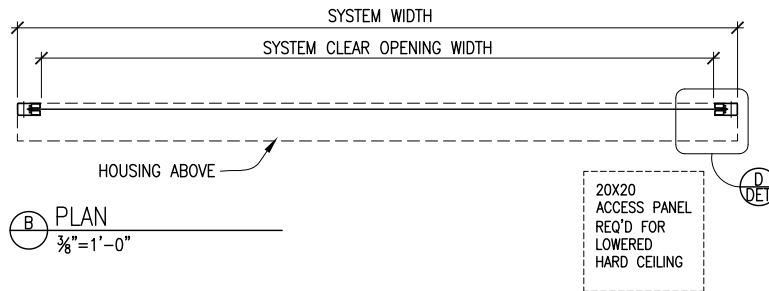

(B) PLAN
3/8" = 1'-0"

1
DESIGN DETAILS M2100
BY: HCK 2.25.2015
M2100.v1.3

